



J P E N T E R P R I S E S

SUPERMATCH™ BARREL KIT

CAUTION

Always wear safety glasses and ear protection while shooting or observing.

Remove the magazine and visually check the chamber before cleaning or working on your rifle to verify that it is not loaded.

When shooting or handling firearms, always observe the four commandments:

1. Treat all guns as if they were loaded.
2. Avoid sweeping yourself or others with the muzzle.
3. Keep your finger out of the trigger guard until ready to fire.
4. Be sure of your target and backstop.

NOTICE

Out of the box, the fitted JP Recoil Eliminator or JP Compensator on your barrel kit will likely appear improperly timed by 20-30°. This is not a manufacturing error and should cause you no alarm. The muzzle treatment has been lightly attached to allow for easy removal during the installation process. During the final fitment steps in this manual, you will securely torque the muzzle brake onto the barrel, at which point it will time up properly level.

Congratulations on selecting one of the most innovative and highest quality barrel assemblies available on the market. JP Supermatch™ barrels are turned from the finest 416 stainless steel alloy and button rifled using state-of-the-art machines. They are then cryogenically treated for cold bore shot predictability, minimum thermal drift, maximum barrel life and outstanding accuracy. The feed ramps of this barrel kit have been polished, and it has been carefully assembled and inspected and found to be properly functioning at time of shipment. Please read the entirety of these instructions before installation and live fire.

JP MUZZLE TREATMENTS

The JP Recoil Eliminator or JP Compensator installed on your barrel kit is designed to reduce or eliminate the felt recoil of the rifle allowing for faster sight recovery time by reducing the movement of the rifle as each shot is fired. This is accomplished by harnessing otherwise wasted kinetic energy from the muzzle gases and directing them against baffle surfaces that redirect them out the sides of the device. The inside forward surfaces of these baffles will show some erosion over time, but this will not affect performance until the exit hole is actually burned through completely. The life expectancy of the barrel may exceed the life of the muzzle brake, and eventually the brake may need to be replaced. Typically, muzzle brakes used on rifles fired in a semi-automatic mode will last about 10,000 to 12,000 rounds.

Muzzle brakes by their very nature redirect high-pressure gases and can blow dirt or other materials present in the shooting area back towards the shooters or bystanders, especially at indoor ranges with enclosed shooting booths. Noise may also be increased to the shooter and definitely to bystanders. Eye protection and earplugs or earmuffs are required equipment when shooting or observing firearms with muzzle brakes or compensators. At indoor ranges, a combination of both earplugs and earmuffs is strongly recommended. There are many good products on the market to fill this need, such as stereoscopic hearing muffs that protect while still allowing you to hear, even while using earplugs. JP Enterprises, Inc. is not responsible for hearing loss resulting from exposure to gunfire.

JP ADJUSTABLE GAS SYSTEM (SELECT CALIBERS ONLY)

The purpose of our adjustable gas block is to allow you to control the pressure delivered to the operating system and thereby optimize the bolt velocity, which will result in a smoother shooting, more reliable rifle, especially in conjunction with a JP Recoil Eliminator or JP Compensator. The ability to adjust the operating pressure also improves the overall reliability and longevity of the operating system. Most rifles cycle faster than necessary, and the resulting "bolt slamming" effect is a noticeable part of the recoil impulse.

As shipped, the gas adjustment screw is set conservatively to ensure function with most loads. When you decide to tune the gas system for a particular load, refer to the specific instruction sheet for your gas block model. These instructions along with a video detailing proper gas block setup can be found on our website. The general setup process is as follows, but our various models have different features, and you should familiarize yourself with those of your model in particular:

1. Use the supplied hex key to turn the gas adjustment screw in all the way to close it. Then, back the screw out about two full turns.

2. Load one round of your ammunition into a reliable magazine and fire. Ideally, the bolt should hold open after the last round of the magazine is fired, meaning the gas block is properly set. This is not likely to happen without some further adjustment, though. If the bolt does not stay open, it is still short-stroking, and the valve should be opened about another quarter turn.
3. Continue to back out the screw until the bolt locks open consistently on the last round. Test again with one round in the magazine. In situations where reliability is critical, we recommend giving it another quarter to a half turn open.

Remember that if you change ammo, port pressure may vary. The rifle should be tested again with any ammunition that you intend to use in actual competition or critical applications like duty use or home defense. If you must use untried ammo, back out the valve a full turn to ensure full cycling. If you want to convert to manual operation to avoid losing brass or peppering the shooter next to you at a formal shooting range, that is another option with this system.

JP *EnhancedBolt*[™] (GAS IMPINGEMENT CALIBERS)

The JP *EnhancedBolt*[™] is made from SAE 9310 high-grade steel and is guaranteed to far outlast standard Mil-spec bolts, which can start to show cracks on the locking lugs after only 3000 rounds. To ensure function and longevity from the *EnhancedBolt*[™], we recommend disassembling, cleaning and inspecting it periodically as part of your standard rifle maintenance. Examine in particular whether any cracks develop around the cam pin hole and locking lug and whether excessive pitting develops on the bolt face extending to the firing pin hole. While some gas erosion is acceptable, excessive erosion in this area is an indication of firing overpressure rounds or reloading brass that is no longer serviceable.

Large-caliber barrel kits ship with the high pressure .308HP version of our *EnhancedBolt*[™]. The design of this bolt differs from a standard .308 bolt by its reduced diameter firing pin hole and companion .062-tipped low mass firing pin. This modified relationship virtually eliminates primer flow and the possibility of pierced primers on any SAAMI or NATO spec. ammunition.

WARNING: The JP .308HP bolt does not allow for the use of excessive pressure/overloaded ammunition that exceeds SAAMI specifications. When evaluating new ammunition, always start on the low- to mid-range of any published load data and work up. A good indicator of working pressure is the primer retention on the subsequent loading of a case. A noticeable loss of primer pocket tension indicates that your ammunition has excessive pressure and has overworked the case.

The specifics of your barrel installation will ultimately be determined by your hand guard and upper receiver combination. The particular attachment method for your hand guard especially will play a large part in how the installation will proceed, so

refer to that product's instructions. (To maximize the accuracy potential of your final build, we strongly recommend free-floating hand guards such as our MK III models.) Because of the numerous possibilities, it is not feasible to provide detailed instructions for every possible combination here. There are many worthwhile publications (both print and web) readily available for proper barrel installation guidance including several instructive online videos. If you are inexperienced and lack the specialized tools for the job, consult a qualified gunsmith for guidance or to have the work done for you. Most accuracy problems with ARs stem from improper assembly.

INSTALLATION

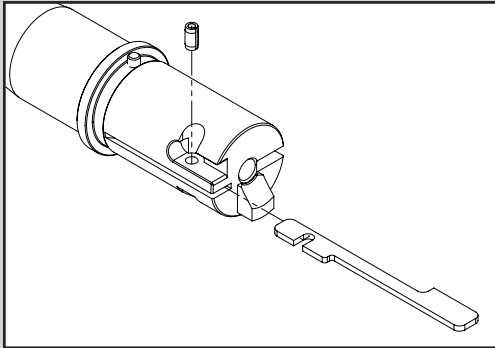

Ejector Installation (.22 LR)

Before installing your .22 LR barrel in the receiver, you must install the included ejector for proper function. Insert the ejector as shown and drive the roll pin in from the top using a hammer and punch.

WARNING: Using the barrel to hold the receiver while tightening the barrel nut either with a barrel vice or a device inside the receiver may lead to damage to the barrel assembly, receiver or both. JP Enterprises will not be liable for damage to barrels, barrel index pins or receivers from improper tightening of the barrel retainer nut. The barrel index pin is intended to align the barrel into the upper receiver during assembly only. It is not a designed or intended to torque the barrel nut into place. The barrel retainer nut should be tightened against the receiver, which needs to be held securely to avoid damage. We recommend the use of the JPVC upper receiver vice clamp jaws to securely hold the upper while torquing the barrel nut.

When you begin the installation of this barrel kit, you'll need to remove both the muzzle treatment and the gas system from the barrel. Neither of these components has been permanently installed and should remove easily. For this reason, you may notice that the muzzle treatment appears improperly timed by 20-30° upon first examination. This is not a manufacturing error and should cause you no alarm.

Once you have the barrel installed in the upper receiver, reattach the gas system as you found it. (For more assistance, the installation instructions for each of our gas blocks can be found online at jprifles.com. Ensure that the gas block is seated against the shoulder of the gas block journal. To align the gas block radially, you can check that both the top rail of the receiver and the gas block align using a level. You can also place the upside down on a flat surface to align the gas block.

With the gas system in place, you can perform the final fitment of the muzzle treatment. Your usage of the muzzle treatment should determine which Loctite® you use for the final installation—271 for a semi-permanent setup or 242 if you'll need to remove the comp more regularly. Apply the Loctite® to the barrel threads and twist the muzzle treatment on hand tight. Then, using an appropriate sized piece of dowel or other non-marring lever into the baffles of the break, torque it until the device clocks correctly and is level. ***Do not use a metal tool such as a wrench for this process as you will almost certainly mar the muzzle treatment.*** No refunds or replacements will be offered for damage of this type. To remove the break, heat the attachment area with a propane torch while applying steady pressure with the dowel or lever until it loosens.

BREAK-IN AND MAINTENANCE

Modern barrel manufacturing techniques result in vastly improved bore finishes and minimize the need for elaborate break-in procedures. Still, we still recommend the following quick process to maximize accuracy potential once your barrel kit is installed.

1. Mop through the bore and chamber before the first firing to ensure that there are no obstructions in the barrel—a worthwhile precaution anytime you fire the rifle.
2. Fire 10-20 rounds followed by cleaning the bore with solvent and applying a bore cleaning product like J-B® Bore Compound, which will have a mild lapping effect on the new barrel.
3. Mop the bore using a clean cotton patch with a little more solvent.
4. Repeat this procedure every 20 rounds for the first 60 rounds, then again after the next 300 rounds.

Bore compound is not necessary for every cleaning thereafter but will serve as an excellent fouling remover if needed. To this end, moly coating (Molybdenum Disulfide) bullets has shown to reduce copper fouling and improve bore life and accuracy. This is an easy process with various readily available kits.

In general, we recommend that you clean the barrel and chamber after every outing with the rifle using an AR chamber brush to remove and residue or brass particles. To protect the chamber, throat and crown of your barrel during cleaning, we offer a high-quality cleaning rod guide precision machined from 6061 aluminum for both AR-15 (JPRG-1) and AR-10 (JPRG-2) platforms.

If at any time you begin to notice light scratching or blemishes on your barrel, products such as Scotch-Brite™ from 3M can restore a uniform brushed finish to the steel.

AMMUNITION

For the best compromise between reliability, safe chamber pressure and accuracy, our .223 Supermatch™ barrels are chambered in .223 Wylde, which is essentially a .223 commercial chamber with a longer throat suitable for match-type projectiles. It will run both 5.56 NATO as well as .223 commercial ammunition. Our .308 Supermatch™ barrels will run both 7.62 NATO and .308 Winchester commercial ammunition. As with any quality rifle or component, the results you can expect will depend on the quality of ammo you're using. While priced well, generic military ball is probably the worst choice, though some people have achieved sub-MOA groups with military fodder. There are many excellent commercial loads on the market today along with outstanding reloading components.

The most common cause of malfunction is out-of-spec ammo, so to help in verifying your ammunition, consider our Semi-Auto Case Gauges made using a chamber reamer just like the one used to chamber our barrel. If you experience failures to go into battery, ignition failures due to light strikes on the primers or difficulty extracting loaded rounds from the chamber when trying to unload, these are all symptoms of casings that have not been sized properly. We can guarantee that if your ammo fits our case gauge, it will fit your chamber. Additionally, we have found that replacing your size die with a Dillon carbide full-length size die will make many of these problems disappear.

No liability is expressed or implied for damage, injury or death resulting from the improper installation or use or misuse of this product.

The handling and use of firearms bears with it certain unavoidable risks, like sky diving and rock climbing. If you are not willing to accept the responsibility for your own actions, guns are not for you.

The use of any custom parts or modifications may void any warranty from the manufacturer of your firearm.

We strongly recommend that the safety and function of your modified firearm be checked by a qualified gunsmith.

Returns will not be accepted on any parts that have been modified.

COMPATIBILITY WITH OTHER COMPONENTS

Due to the abundance of aftermarket accessories introduced every year by hundreds of manufacturers, it is impossible for us to provide accurate compatibility information for ALL our components with ALL other manufacturers' products in ALL possible combinations. Some simple measurements, a visual examination and some common sense can save a lot of time, and it is ultimately your responsibility to verify compatibility of the parts you intend to use. The only assurance we can give is that JP products are compatible with other JP products. If you find that the particular JP component you've ordered is not compatible with the others that you wish to use, you can return it to us in unused condition along with the original packaging for a refund.