



REPLACEMENT STEEL/TUNGSTEN WEIGHT SILENT CAPTURED SPRINGS VARIABLE MASS OPERATING SYSTEM

CAUTION: REMOVE THE MAGAZINE AND VISUALLY CHECK THE CHAMBER TO ENSURE THAT YOUR FIREARM IS UNLOADED.

These instructions will walk you through the disassembly of the buffer weights in either your Silent Captured Spring unit or Variable Mass Operating System (VMOS™) bolt carrier. Reconfiguration of these weights allows mass regulation to suit your particular setup.

The alternative tungsten weights can replace the standard steel components of the JPSCS or VMOS™ unit for an increase in the reciprocating mass of the operating system. This changeover is especially useful for eliminating the symptoms of bolt bounce during cycling. In the SCS, replacing the steel weights with tungsten allows the unit to function in place of a conventional H2 (2 tungsten, 1 steel) or H3 (3 tungsten) buffer and spring for systems requiring that extra mass.

SILENT CAPTURED SPRING

1. Compress the buffer spring by hand and grip the guide rod in a soft padded vise where shown. Take care to grip the unit securely with the spring under tension in this way or it may take flight. On later runs of JPSCS units, you can also retain the mass slider by inserting an appropriately sized pin or tool into the hole located near the center of the guide rod.
2. Remove the guide rod screw. Depending on the production run of your SCS unit, you may need to break down the thread locker if you cannot remove the screw easily. If the thread locker is too strong, apply heat with a propane torch to the guide rod while using a wrench to apply turning pressure to the guide rod screw.
3. Remove the hex key from the guide rod while retaining the compressed mass with your hand. The spring pressure is approximately 15 lbs., so point these components away from your face as a precaution in case they fly apart.
4. Slowly relax the spring and remove both the spring and buffer mass from the guide rod.
5. Remove the snap ring from the SCS mass assembly by using the tip of a small screwdriver to pry up the end of the ring and slide it off the back side of slider. Once the tip is off, the ring should remove easily by working it in an unwinding fashion.

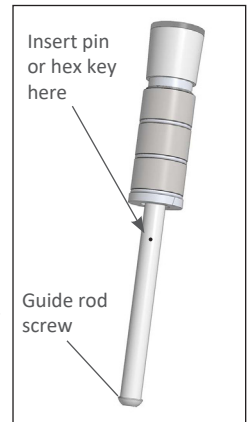

6. Replace one or more of the existing steel weights with the tungsten weights taking care to retain the placement of the rubber O-rings. One O-ring should be positioned on every side of the weights except in the space between the weight and the snap ring.
7. Reassemble the mass slider by replacing the snap ring.
8. Reassemble and re-secure the SCS unit using a hex key as you did in step 1. Clean the guide rod threads and screw with solvent and dry completely. Install the guide rod screw with thread locker and tighten the screw to 40-60 in-lbs. Some newer SCS kits come with screws pre-loaded with thread locker. The pre-loaded thread locker is only reusable two or three times. If you need to apply thread locker, we recommend a semi-permanent product such as Loctite® 243.

During regular rifle maintenance, check the tightness of the hex head screws at the ends of the JPSCS. The rear screw should be installed with a permanent thread locker such as Loctite® 263. the front flange screw is better secured with a semi-permanent thread locker like Loctite® 243.

VMOS™ BOLT CARRIER

1. Remove the snap ring from the end of the bolt carrier using the tip of a small screwdriver to pry up the end of the ring and slide it off the back side of slider. Once the tip is off, the ring should remove easily by working it in an unwinding fashion.
2. Replace one or more of the existing steel weights with the tungsten weights taking care to retain the placement of the rubber O-rings. One O-ring should be positioned on every side of the weights except in the space between the weight and the snap ring.

The steel mass abutting the snap ring is specially chamfered to ensure cycling. **This steel mass must remain in this position with the chamfer facing the rear as shown.** Replacement of this steel weight with a tungsten one is not possible.

3. Reassemble the mass slider by replacing the snap ring.

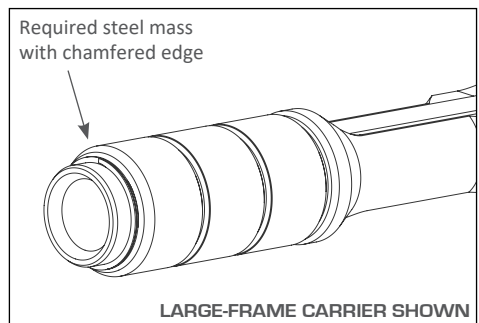

THANKS FOR YOUR BUSINESS!

