



# JP ENTERPRISES

Product:  
JPSCS2-15K,  
JPSCS2-10K.

## GEN 2 SILENT CAPTURED SPRING ASSEMBLY KIT

US Patent Number 8,800,424

### PARTS INCLUDED

- Silent Captured Spring
- Rifle-length spacer
- Alternate rate springs
- Spacer shim

**CAUTION: REMOVE THE MAGAZINE AND VISUALLY CHECK THE CHAMBER TO ENSURE THAT YOUR FIREARM IS UNLOADED.**

### WARNING

The Silent Captured Spring unit in this kit has been only partially assembled. The screw retaining the mass slider and spring must be secured with thread locker before final installation of the JPSCS. Some newer SCS kits come pre-loaded with thread locker. If you need to apply thread locker, we recommend a semi-permanent product such as Loctite® 243. **Do not install the JPSCS for regular use without securing this screw with thread locker.**

The **JP Silent Captured Spring** is a drop-in module replacement for the traditional buffer plunger and buffer spring components of the AR-15 and AR-10 platforms. By all but eliminating the raspy scraping of the buffer spring against the interior of the extension tube, the JPSCS yields a virtually silent cycling action with a dramatic reduction in friction and vibration during live fire. This complete assembly kit includes the JPSCS unit with several alternate rate springs to facilitate more precise tuning and refinement of your rifle's cycling.

The JPSCS is designed and intended for semi-automatic use only and is not recommended for full-auto applications. Also, While the JPSCS has been tested in numerous rifles without malfunction, this is no guarantee of function in all rifles. As with any gas gun component, there are simply too many possible rifle configurations, barrel lengths and calibers available within both the AR-15 and AR-10 platforms to test and verify universal function of the JPSCS system. **If you're unsure about compatibility, see the SCS Selection Guide on our website for known issues before live fire.** If the unit does not function in your rifle, please contact JP via phone or email to arrange a return of the JPSCS to the original point of sale.

### COMPARATIVE JPSCS SPRING RATES

	AR-15	AR-10
<b>HEAVIER</b>	JPSCS-15-80 White - Uncolored	JPSCS-10-100 Red - Uncolored
	JPSCS-15-85* Black - Uncolored	JPSCS-10-105 Red - Blue
	JPSCS-15-90 Green - Uncolored	JPSCS-10-110 Red - Yellow
	JPSCS-15-95 Yellow - Uncolored	
	JPSCS-15-100** Uncolored	

\* JPSCS2-15  
\*\* JPSCS2-15H2

## JPSCS ASSEMBLY INSTRUCTIONS

The following steps will detail how to assemble the JPSCS unit in order to change out the operating spring. As a general rule for selecting an alternate spring, install a heavier spring if you feel the buffer head fully compress and bottom out while firing the weapon with the existing spring. If the bolt carrier will not lock back reliably on the last round fired even when completely gassed (in the case of an adjustable gas block), select a lighter spring. The ends of the springs have been color-coded for ease of identification. To ensure your intended result, refer to the preceding table. Be aware that with repeated use, the coloring will wear off these springs, so you may wish to label them.

1. From the springs provided, select one from the table above. The highlighted springs represent the default option we use and are a good starting point.
2. Insert the spring onto the guide rod and compress it completely with the mass slider until it reaches the bumper. Then, insert a hex key or other tool into the hole through the guide rod to retain the mass. For your ease, you may wish to secure the JPSCS in a vise for this step. The spring pressure is approximately 15 lbs., so point these components away from your face as a precaution in case they fly apart.
3. Install the guide rod screw and tighten it securely to retain the mass slider. The head of this 10-32 screw takes a T25 key. With this screw installed, remove the hex key from the guide rod.
4. Install the JPSCS into your rifle as described in the installation instructions. With your rifle reassembled with the SCS, test fire a few rounds to assess the function with the current spring.
5. When you are satisfied with your spring selection, clean the guide rod threads and screw with solvent and dry completely. Install the guide rod screw with thread locker and tighten to 40-60 in-lbs. Some newer SCS kits come with screws pre-loaded with thread locker. The preloaded thread locker is only reusable two or three times. If you need to apply thread locker, we recommend a semi-permanent product such as Loctite® 243. If applying new thread locker, follow the accompanying instructions.

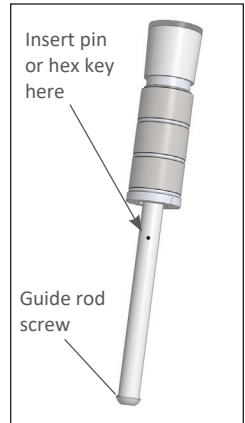

## JPSCS INSTALLATION INSTRUCTIONS

### REMOVAL OF BUFFER RETAINER PLUNGER AND SPRING

While the JPSCS will function with or without them, you can remove the buffer retainer plunger and spring at this point. With these components removed, installation and removal of the JPSCS is much easier, though be aware the traditional buffer and spring components will be cumbersome to use without the retainer and plunger.

To remove the retainer plunger and spring, you'll first need to remove the stock and buffer tube from the receiver to gain access, after which you can reinstall the extension tube and stock taking care not to lose or damage the rear takedown pin detent and spring.

1. Remove the existing buffer and spring by slightly compressing the buffer and then compressing the buffer retainer plunger with a small punch. Release the buffer slowly, removing it and the buffer spring from the extension tube.
2. If you are using a rifle-length stock and extension tube, insert the white spacer into the extension tube. This spacer is not needed for carbine stocks/tubes.

3. Insert the JP Silent Captured Spring into the buffer tube oriented as shown. You may have to depress the hammer to the cocked position or a little further to allow enough clearance around the trigger components. Likewise, on certain two-stage triggers, you will have to hold the hammer in the half-cocked position to achieve sufficient clearance.

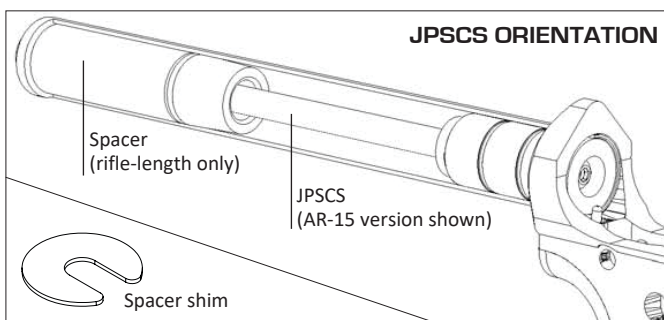

4. Reassemble the upper and lower assemblies with the front pivot pin and slowly lower the upper into position. Watch carefully as the receivers are closed to verify that the SCS buffer head contacts the bolt carrier. If you are not certain if there is a gap, finish reassembling the rifle and then shake it back and forth gently, listening for the sound of the SCS sliding back and forth in the buffer tube. The unit should not be moving freely.

The precise length of the SCS was chosen to accommodate most rifles, but if you detect a gap between the bolt carrier and SCS, this is due to slight variations in the manufacturing tolerances of the buffer tube, bolt carrier and receivers.

The SCS should protrude about .030", which is the width of the included spacer shim. If it does not protrude this far, insert the spacer shim behind the SCS in the buffer tube. It will not be necessary to use more than one, and you should not use extra shimming to "preload" the SCS. We offer alternate rate springs for this purpose.

If the SCS protrudes past .060" inches or so (the approximate width of a quarter), thread the buffer tube out one turn and recheck protrusion and add the spacer shim if necessary.

## JPSCS DISASSEMBLY INSTRUCTIONS

1. Compress the buffer spring by hand and insert a hex key or other suitable tool into the hole through the guide rod to retain the mass. For your ease, you may wish to secure the JPSCS in a vise for this step.
2. Remove the guide rod screw (see diagram on pg. 2). In some cases, you may need to break down the thread locker if you cannot remove the screw by hand. If the thread locker is too

strong, you'll need to break this down by applying heat with a propane torch to the guide rod while using a Torx wrench to apply turning pressure to the screw. Once the screw breaks loose, remove the heat source and the screw.

3. Remove the hex key while retaining the compressed mass with your hand. As stated earlier, be sure to point these components away from your face as a precaution in case they fly apart.
4. Slowly relax the spring and remove both the spring and buffer mass from the guide rod.
5. If needed, remove any remaining thread locker on the guide rod and screw by cleaning the guide rod in lacquer thinner, acetone, brake cleaner or equivalent. Allow the part to air dry or blow the threads out with compressed air to remove solvent.
6. Repeat the assembly instructions with another spring as desired. When you have made your final selection, complete step 5 of the assembly instructions.

## **FITMENT**

The precise length of the SCS was chosen to accommodate most rifles, but if you detect a gap between the bolt carrier and SCS, this is due to slight variations in the manufacturing tolerances of the buffer tube, bolt carrier and receivers. The bolt carrier and SCS should be tensioned slightly against each other in final assembly and should not move freely in the rifle.

The SCS should protrude about .030", which is the width of the included spacer shim. If it does not protrude this far, insert the spacer shim behind the SCS in the buffer tube. It will not be necessary to use more than one, and you should not use extra shimming to "preload" the SCS. We offer alternate rate springs for this purpose.

If the SCS protrudes past .060" inches or so (the approximate width of a quarter), thread the buffer tube out one turn and recheck protrusion and add the spacer shim if necessary.

## **MAINTENANCE**

To achieve the utmost from the JPSCS, keep the spring, guide rod and exterior of the unit lightly oiled. If the unit becomes fouled, clean with hot, soapy water, blow dry with compressed air and apply light oil (rather than grease) to the spring and guide rod. Do not clean the SCS with solvents or solvent-based cleaners. These will dry out and degrade the rubber o-rings, reducing their life expectancy.

During regular rifle maintenance, check the tightness of the hex head screws at the ends of the JPSCS. If they are loose, remove them and clean the threads. The rear screw should be installed with a permanent thread locker such as Loctite® 263. The front flange screw is better secured with a semi-permanent thread locker like Loctite® 243.

**THANKS FOR YOUR BUSINESS!**