



# J P E N T E R P R I S E S

## JP ADJUSTABLE GAS SYSTEM

.750 bore steel, dial adjustable

### PARTS INCLUDED

- .750 bore gas block (upper and lower pieces)
- Gas valve dial with gas tube installed
- Eight (8) 6-32 x 1/2" socket head cap screws
- T15 Torx key

### INSTALLATION INSTRUCTIONS

**CAUTION: REMOVE MAGAZINE AND VISUALLY CHECK CHAMBER TO MAKE SURE THAT FIREARM IS UNLOADED.**

The JPGS-6 Adjustable Gas Block is designed for use on .750 contour barrels. Unlike other JP gas blocks that use a continuously adjustable set screw, the adjustment of the JPGS-6 is made via a dial transitioning between three discrete valve openings and is tailored for rifles requiring quick and easy transition between suppressed and unsuppressed fire. Note that the gas tube for the JPGS-6 is preinstalled is straight, unlike standard gas tubes, to allow in-line rotation of the gas block's valve dial.

This gas block model is designed to be installed and custom tuned by a gunsmith and is not furnished by JP Enterprises with tuned gas ports. Tuning the gas ports involves drilling ports in the gas valve and may involve opening up the gas port in the barrel itself, which must be done in conjunction with live fire testing. Please read through the instructions completely before you begin the installation, and make sure you are comfortable with the process before beginning. We highly recommend that you have some experience with tuning rifles with conventional adjustable gas blocks before attempting installation and tuning of the JPGS-6. Before installation measure and record the gas port size of your barrel since you will need this for reference.

### INSTALLATION

1. Clean and degrease the block journal on the barrel and mating surface of the upper gas block. Note the orientation of the gas block, the cutout for the gas adjustment valve faces to the front.
2. Slide the lower gas block strap into position on the barrel, making sure to orient it such that the screw holes will line up with the upper gas block. You'll notice that the holes for the rearmost screws are closer to the edge than the front holes. The bottom strap wraps around the barrel enough that it should be slid on from the front, but it will stay on the barrel while you attach the gas valve body.
3. Apply a thin layer of Loctite® 272 (or equivalent) high-temperature stud locker to the mating face of the barrel and upper gas block. This will act as a sealant to help prevent gas leakage and also help prevent any migration of the gas block.
3. Set the gas block in position and install the screws, lightly tightening them in the order shown until they are just snug. Take care to keep the gap between the gas block and strap even.
4. Before tightening the gas block completely, ensure that the rail on the gas block is level with the rail on the receiver. The easiest way to do this is to set the rifle (rail down) on a flat surface and wiggle the gas block until it is level with the upper receiver. Then, tighten the screws a little at a time following the pattern on the diagram until they are all tight and even. The final torque should be around 18-20 inch-pounds.
4. With the gas block installed, remove any excess Loctite® that may have been displaced around the gas block to barrel mating surface, especially in the gas port itself. Spray degreasers like Gun Scrubber work well to flush out the gas port, but be sure to clean out the barrel as well if you spray any cleaner into the gas port.

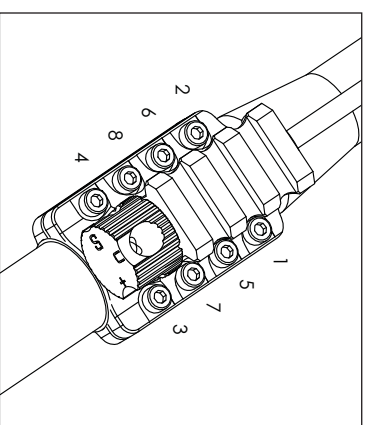

### GAS BLOCK SETUP

Most gas-operated rifles cycle faster than necessary with the resulting "bolt slamming" effect causing a noticeable part of the recoil impulse. The main purpose of an adjustable gas block like the JPGS-6 is to allow adjustment of the port pressure to the operating system, thereby tuning the bolt velocity to achieve a smoother shooting rifle.

Visit us at [www.jpprofiles.com](http://www.jpprofiles.com)

P.O. Box 378, Hugo, MN 55038 • VOICE: 651-426-9196 • FAX: 651-426-2472

Rev. 05.14

The presets of the JPGS-6 are for operating the rifle in set modes and are noted on the dial face along with varying sizes of scallop depth that indicate comparative size of the gas openings. In ascending order of hole size, these are: suppressed (S), unsuppressed (U) and open or “dirty” (+) to allow maximum gas with a corresponding increase in recoil impulse. There is also an unmarked setting opposite the (U) to turn the gas system off, allowing the rifle to run manually with the charging handle.

Each of the gas holes in the valve is reamed to a nominal size: .052” (S), .067” (U), .073” (+). These may or may not function on your particular rifle without modification. The following steps will walk you through determining whether modifications are necessary as well as how to perform them. Remember that if you change ammo, the rifle may not cycle reliably and should be tested again.

1. Ream or drill the (+) port to the size of your gas port, which you noted on the first page. **Note that this is the port on the opposite side of the valve cylinder from the (+) on the dial.** Refer to the diagram at right.
2. Install the gas valve into the body by sliding the valve, gas tube first, down through the hole in the valve body and feeding the gas tube into the receiver.
3. With the valve in place, install the E-clip retaining ring into the groove on back end of the valve where it protrudes from the body. The valve will hit the detent spring just before it is all the way in, and you will have to push the valve to compress the spring to insert the E-clip. Verify that the valve can be turned and adjusted. A bullet nose can be used as a tool to rotate the valve if needed since it may be quite tight when new.

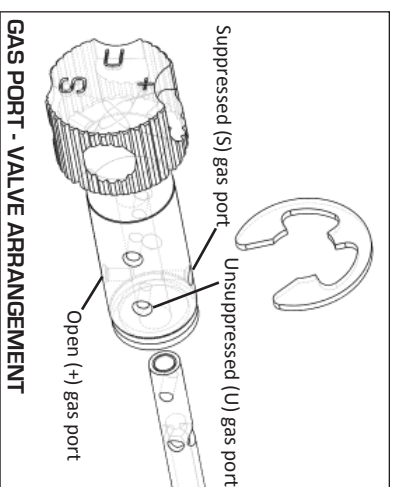

### GAS BLOCK TUNING

Increasing the valve openings of the JPGS-6 involves removing the dial from the gas block and then opening up the appropriate gas holes until proper function is achieved. If your rifle is used for law enforcement or military purposes, we recommend erring on the side of larger valve openings so as not to compromise reliability.

The valve dial itself is manufactured from 4140 steel, so standard reamers and a power drill should be adequate for the task. When performing this process, it is imperative to keep the following in mind to avoid ruining the part:

- The hole corresponding to a given setting on the valve dial is located on the opposite side of the cylinder from the indicator on the dial itself. Refer to the diagram.
- Adjustments should be made in small increments of one nominal drill size at a time. You can't make the openings smaller once you have them opened up.
- When reaming the holes, make sure you only go deep enough to open the specific hole you're working on and the gas tube. Stop drilling once you reach the gas tube's center or you may affect the hole in line on the opposite side.

1. Remove the valve dial and gas tube by first removing the E-clip on the rear of the gas block securing the valve in place. The dial should then slide out unhindered.
2. Open up your intended hole by reamer one nominal drill size larger than it will accommodate freely.
3. Reinstall the valve and repeat the one round test to verify function of the hole you just opened. If the bolt locks back, no further modification of that hole is necessary. If the bolt does not lock back, continue opening up the hole incrementally until the bolt locks back consistently on the last round.

With the gas block installed and the open (+) port drilled, you will next have to conduct multiple test firings and adjustments to tune the JPGS-6 presets to your particular rifle and suppressor. Following the directions in the sidebar, adjust the port sizes for the suppressed (S) and unsuppressed (U) settings with and without your suppressor, respectively. Open each hole incrementally desired operation is achieved. Note that you will have to remove the gas block and enlarge the barrel gas port as well if the open (+) setting needs adjustment.

When you are finished and confident that you have the settings where you want them, the gas block screws should be removed one at a time and then reinstalled and torqued down with Loctite® to prevent loosening.

If you must use untried ammo through your JPGS-6-equipped rifle, use the open (+) setting for maximum gas and full cycling. Remember that it is also possible to shut the valve completely if you want to cycle the rifle manually.

Finally, be aware that a new rifle or bolt assembly will have a great deal of friction between the gas rings and carrier and may require a break-in period during which the gas block must be run wide open for complete cycle. Since the path through the gas block is a bit longer than a standard front sight manifold, it is a bit less efficient initially. A new rifle with an extremely stiff bolt may not cycle completely until broken in. It helps to polish the bore of the carrier on a new bolt to reduce this friction and mate the parts.

**THANKS FOR YOUR BUSINESS!**

Visit us at [www.jprrifles.com](http://www.jprrifles.com)

P.O. Box 378, Hugo, MN 55038 • Voice: 651-426-9196 • Fax: 651-426-2472