



CAUTION: REMOVE MAGAZINE AND VISUALLY CHECK CHAMBER TO MAKE SURE THAT FIREARM IS UNLOADED.

This competition magazine catch for the GMR-15™ lower receiver easily replaces the standard magazine catch and offers a larger profile for easier access and exaggerated texture for better grip.

To replace your current GMR-15™ magazine catch, we recommend using a 3/32" and a 1/8" punch. An extra 3-32 x 1" roll pin is included in this package in case the existing one is lost or damaged.

1. Secure the magazine catch lever prior to driving out the pivot roll pin. Once the pin is removed, the spring tension will cause the catch and spring to eject if not secured.
2. Use a 3/32" punch to drive the existing roll pin out of the receiver through the hole in the top. A 3/32" roll pin starter punch is best, if available.
3. Use a 1/8" punch to just start the pivot roll pin in the hole from the top.
4. Replace the standard lever with the new extended lever, reusing the existing spring.
5. Insert the 3/32" punch from below of the receiver to retain the catch as a drift pin.
6. Drive the pivot roll pin in the rest of the way using the 1/8" punch. This will drive out the 3/32" punch. Drive the roll pin in **only until you meet resistance**. Internal features will prevent over-insertion.

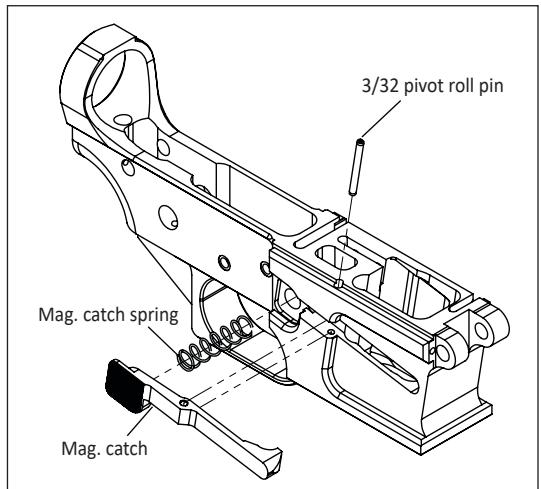

**THANKS FOR
YOUR BUSINESS!**