



34mm FLAT-TOP SCOPE MOUNTS

- JPFTSM-34 (Standard)
- JPFTSM-34E (Extended)
- JPFTSM-34-20 (20 MOA)

PARTS INCLUDED

- Lower mount saddle
- Mounting clamp plate
- Two (2) upper strap pieces
- Five (5) 8-32 x 1 1/4" flat head screws
- Twelve (12) 6-32 x 1/2" socket head cap screws
- T10 Torx key
- T20 hex key

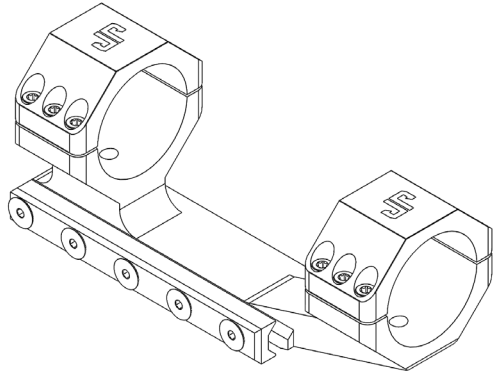

CAUTION: REMOVE MAGAZINE AND VISUALLY CHECK CHAMBER TO MAKE SURE THAT FIREARM IS UNLOADED.

Before attempting to install this mount, be aware that some receiver rails fall significantly outside the specifications for MIL-STD-1913 rail and may not accept this mount without modification.

1. Position the scope mount body onto your receiver rail. If the recoil lug does not rest into the rail without force, your rail is not within spec, and the recoil lug may have to be modified to make the mount compatible with your receiver.
2. Insert all five of the clamp plate mounting screws through the clamp bar and begin threading each into the holes of the mount body using the supplied T20 Torx wrench. Note the orientation of the clamp bar as it is not symmetrical.
3. Secure the mount to the rail starting with the center screw and proceeding outward to secure the four remaining screws. Tighten each screw partially until a uniform torque of 30 inch-lbs. is achieved. There is no need for a thread locker, but you may use Loctite® 242 if you want a semi-permanent installation for your optical system and do not intend to remove it on a regular basis.
4. Place the optic in the lower saddle and position the upper straps on top of it. Engage all twelve socket head screws, but do not tighten them.

Typically, when inserting the scope within the mount rings, the best mounting position locates the scope as far forward as possible. Take this time to position and level your optic as appropriate.

5. With the scope positioned and level, start tightening the socket head screws with the T10 Torx wrench. Make sure to keep the gaps uniform on both sides of the mount so that the strap tightens evenly and remains level. Tighten the screws snugly according to the order indicated in below, beginning with the center screws followed by the outer screws on opposing corners. Screws should be tightened to 12-15 inch-pounds of torque unless the manufacturer of your scope advises otherwise.

As a final precaution, we also recommend the use of Loctite® 242 or equivalent (available from JP or at your local hardware store) on the top strap retaining screws and to prevent loosening from the vibration of live fire.

As illustrated below, our scope mounts can be equipped with our **JPoint Microelectronic sight** via a piggyback mounting setup. In the case of our 34mm mounts, the top straps of the mount are manufactured with four 6-32 holes, and using our JPA-Guard protective wing mount, the JPoint sight can be mounted using the hardware included with the JPA-Guard.

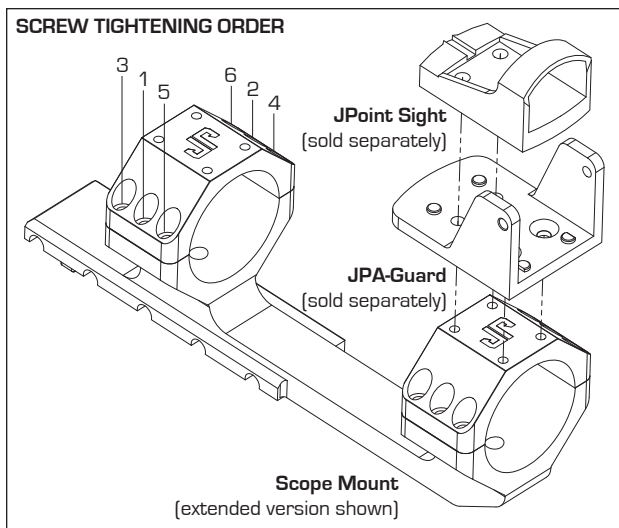

THANKS FOR YOUR BUSINESS!